

FORGING HAMMERS



DIRECT SPRING SUPPORT OF FORGING HAMMERS



Spring -Viscodamper® Combination

Forging hammers are designed to generate large dynamic forces with every hammer blow. Conventionally designed foundations require a relatively large, heavily reinforced concrete block to transmit the impact force into the soil. The size of the foundation block depends on the impact energy produced by the hammer, and on soil conditions.

Vibrations resulting from the hammer blow are also transmitted directly into the soil. These vibrations may have a detrimental effect on nearby equipment and operating personnel, and even on nearby residences. Vibrations may also cause the foundation to settle, and the hammer to tilt.

Many years ago, GERB developed a vibration isolation technology for forging hammers, featuring helical steel springs and viscous fluid dampers. Early elastic foundation systems required an inertia mass under the hammer. Through continuous research and development, GERB was able to develop a direct spring support system, eliminating the need for the inertia mass.

Direct spring support systems are now used worldwide on over 1000 hammers with blow energies up to 400 kJ. GERB-spring-Viscodamper® combinations effectively isolate hammer vibrations, and bring the hammer to rest before the next blow. Springs and damper are combined into a single element. The viscous damping fluid is practically unaffected by temperature changes. Damping capacity is constant, even in continuous operation.

The spring-Viscodamper® system system is nearly maintenance free. Nearly all hammers, including belt-driven drop hammers and one-column, air-driven hammers, can operate on the direct elastic foundation system.

Advantages include:

- » Considerable reduction in construction time and cost. The foundation block is no longer required, and the foundation pit is much smaller.
- » Equipment (hammers, presses, and sensitive equipment) can be installed in close proximity.
- » Production cycles are improved. Hammers can operate with faster blow rates, and can be operated for longer periods of time.
- » Vibrations are reduced by at least 80%, compared to conventional foundations.
- » Foundation settlement and tilting are eliminated.

GERB offers:

- » Elastic foundation design
- » Worldwide supply of spring-Visco-damper® systems
- » Complete civil engineering support, including vibration surveys and assessments, soil assessments, and pit design, including general arrangement drawings, reinforcement drawings and rebar schedules
- » Installation or installation supervision.

Conventional Foundation

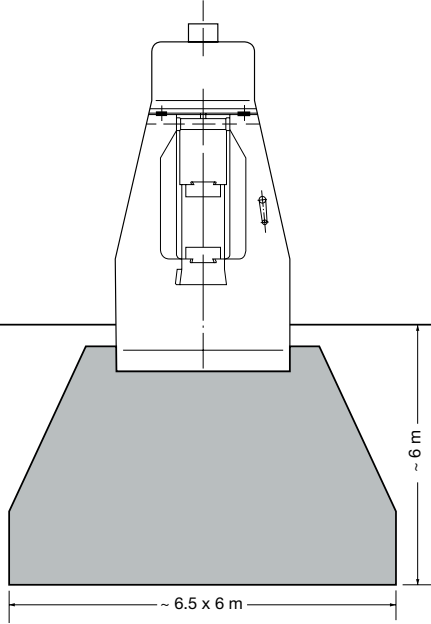

Spring Supported Hammer with Inertia Block

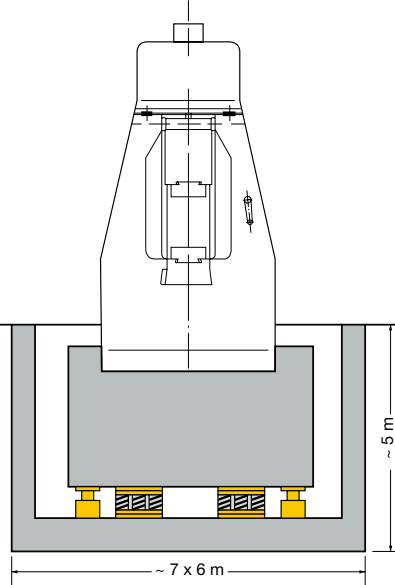

Direct Spring Support

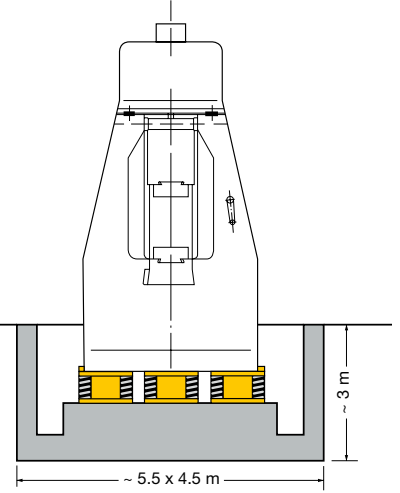

Spring Supported Schuler Linear Hammer

Typical System Response of a Spring Supported Hammer

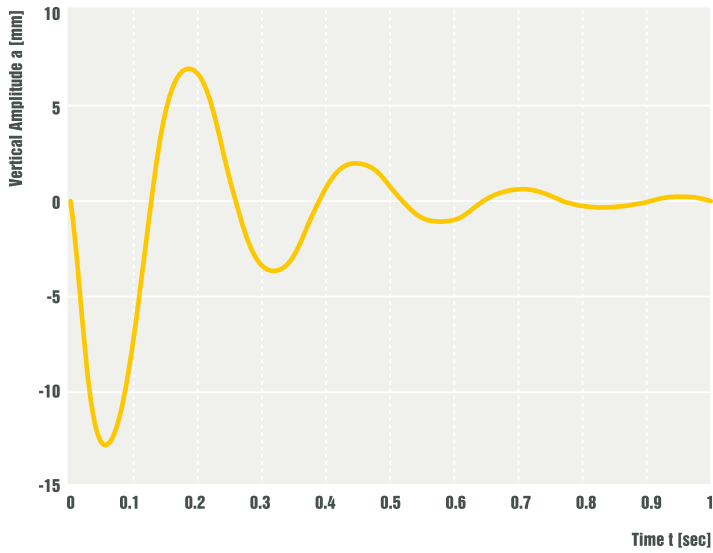

Spring Supported Otani-Hammer



Spring Supported Bêché-Hammer



Spring Supported Erie-Hammer

GERB spring support protects your neighbourhood. The diagram shows vibration values of hammers with and without GERB isolation system.

Vibrations are reduced by more than 80% compared to rigid foundation.

Measured Vibrations (Velocities) of Forging Hammers (in a Distance of 10 m)

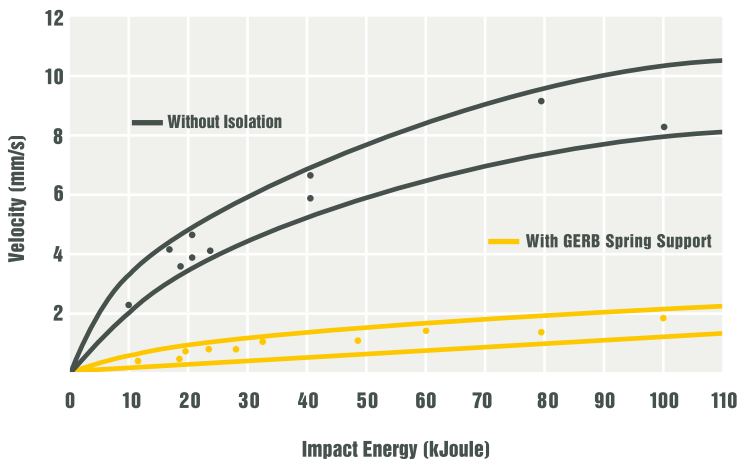

Spring Support of a Forging Hammer with Additional Steel Plate



Spring Supported Fully Automatic Lasco Hammer

Reference List (Excerpt)

Direct Spring Support of Forging Hammers

Country	Customer	Manufacturer	Capacity (kJ)
Argentina	CRAFMSA	Chambersburg	250 + 320
Australia	Heggie/Westray	Eumuco	40
Austria	Steyr-Daimler-Puch	Lasco	20
Brazil	Forja Rio	Huta Zygmunt	175
Canada	IMP Aerospace	Chambersburg	45; 58; 125
Chile	Conmetal L.T.D.A.	Schuler Bêché	30
China	Asian Star Anchor Chain Shandong Jiuxin Tools Baicheng Zhongyi Precise Forge	Anyang Forging Press Mach. China Forging Machinery Jiangsu Baixie Forging Equipment	25; 80; 125; 200 100 2 x 25
France	Bar-Lorfogees Raymond Barre	Lasco Banning/Lasco	50 16/2 x 100
Germany	Hammerwerk Fridingen	Schuler Bêché	40 - 80
	Brockhaus	Lasco	25 - 63
	Halbach	Schuler Bêché	25
	Hüttebräucher & Herfel	Lasco	80
	Broch Adler	Lasco	20 - 40
	Knipex Werke	Lasco	20 - 50
	RUD Schöttler Carl Sülberg	Schuler Bêché Schuler Bêché	20 31.5 - 50
Great Britain	A. Edge Joseph Shakespeare	Lasco Massey	12.5 50; 60
Hungary	Raba Győr	Lasco	63; 40
India	Delhi Forge Sadhu Udvoa	Rattan Woronesh	62 125 + 310
Indonesia	Astra Tech P.T. SGI	Huta Zygmunt Otani	36 95
Italy	Pietro Rosa T.B.M. Varesina Stampi S.p.A.	Maglio Pensotti Huta Zygmunt	150 175
Japan	Okumura Forge	Otani	220
Korea	Dae Chang Dai-A-Metal Works	Nitta Sanwa	140 + 400 52
Norway	Kongsberg	Lasco	20
Schwitzerland	Delhi Forge Sadhu Udvoa	Rattan Woronesh	16
Spain	EUROTOOLS	Lasco	5 x 20
Taiwan	Tzei Pon	Huta Zygmunt	125; 175
USA	Autoforge Forgings & Stampings Trinity Forge	Chambersburg Lasco Lasco	31 16; 20; 25 80



GERB Schwingungsisolierungen GmbH & Co. KG

Roedernallee 174 – 176 Ruhrallee 311
13407 Berlin, Germany 45136 Essen, Germany
+49 30 4191-0 +49 201 26604-0
info@gerb.com info@gerb.com

GERB.COM

©GERB Schwingungsisolierungen GmbH & Co. KG | All rights reserved.
Certified to: ISO 9001 ISO 14001 DIN EN 1090 BS OHSAS 18001

**VIBRATIONS CAN BE CONTROLLED
– WHEREVER THEY OCCUR**

For preparation of a design proposal please provide the following information:

- » Type and manufacturer of hammer
- » Total weight of hammer
- » Impact energy
- » Weight of ram
- » Dimensions of anvil
- » Depth of anvil below floor

Any additional information will help us to optimize our proposal.